

PRORIL

60Hz

GOBITS Series, these grinder pumps meet the demanding needs of commercial and residential sewage applications. GOBITS series pumps employ a grinding mechanism to effectively grind and transfer solids under high pressure from one place to a higher or a distant place. Ideal for residential and low-pressure sewer applications.

Sewage Pump

GOBITS 15/22

Grinder Pump



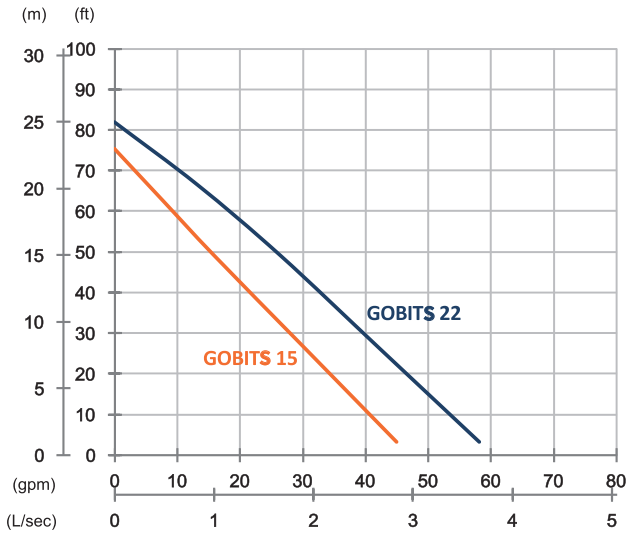

	GOBITS 15	GOBITS 22
OUTPUT	2 HP (1.5 kW)	3 HP (2.2 kW)
OUTLET	1.25" (32 mm)	2" (50 mm)
Weight	77 lbs/35 kg	77 lbs/35 kg
HEAD	Rated: 49 ft, 15 m Max: 75 ft, 23 m	Rated: 49 ft, 15 m Max: 82 ft, 25 m
FLOW	Rated: 16 gpm, 1 L/s Max: 45 gpm, 2.8 L/s	Rated: 26 gpm, 1.7 L/s Max: 58 gpm, 3.7 L/s

Pump Type	Electric Submersible Pumps	
Motor	Phase	1-Phase, 3-Phase
	Type	Induction Motor
	Poles	2 Pole (3450 rpm)
	Insulation	Class F
	Protector	Circle Thermal Protector
	Starter	1-Phase · Capacitor-Start (15), 3-Phase · D.O.L.
Lubricant	Food Grade (ISO VG32)	
Specs.	Impeller Type	Vortex
	Shaft Seal	Double Mechanical Seal Silicon Carbide VS Ceramic/Carbon
	Bearings	C3 Shielded ball bearings
	Cable	CSA-Certified PVC Jacketed Cables 33 ft (10 m) or longer upon request
Materials	Pump Casing	Gray Iron
	Impeller	Gray Iron
	Motor Frame	Gray Iron
	Motor Shaft	Stainless Steel
	Grinder Set	Chromium Iron
Max. Liquid Temperature	40°C (104°F)	
Max. Submersion Depth	20 m (66 ft)	
pH Range	pH 5 - pH 8	
Guide Rail	GRL-02	

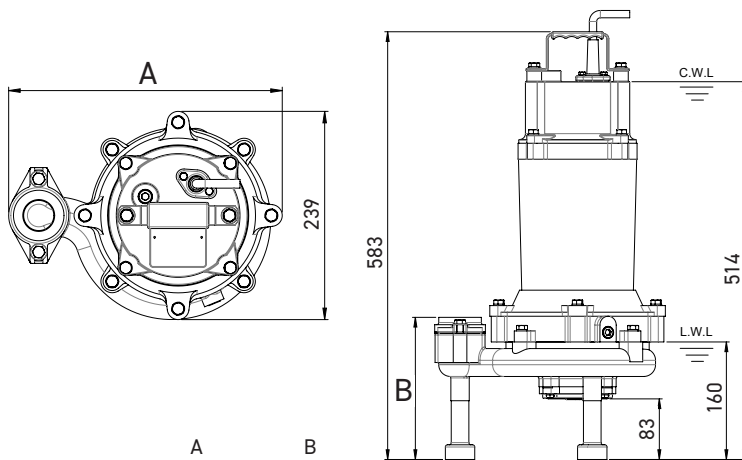

	A	B
GOBITS 15	314	194
GOBITS 22	316	198

unit : mm
C.W.L : Continuous running water level
L.W.L : Lowest running water level